

PT Mount

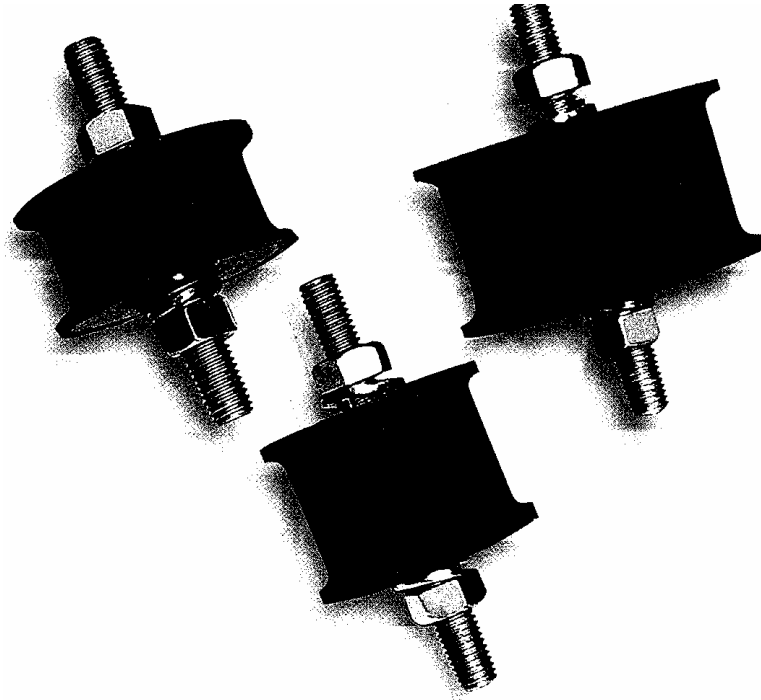

Multi-purpose Application & Economical

Wide Load Range

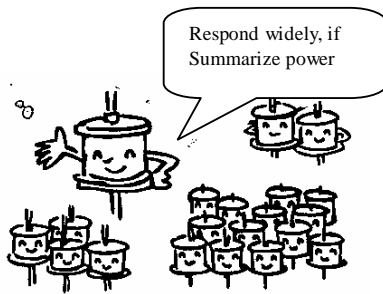

Multi-purpose Application at Low Cost



Feature

- Very simple structure and higher efficiency for Vibration-proof.
- Available for vibration from lightweight to large equipment.
- Can be used outdoor by using weatherproof rubber.

Application

Vibration-proof rubber placed on floor for Pump, Air conditioner, Blower, Motor, Compressor, Horizontal piping and Vertical piping, etc.

General-purpose vibration-proof rubber use for installation between upper/lower pedestals made of steel.

Example for Installation

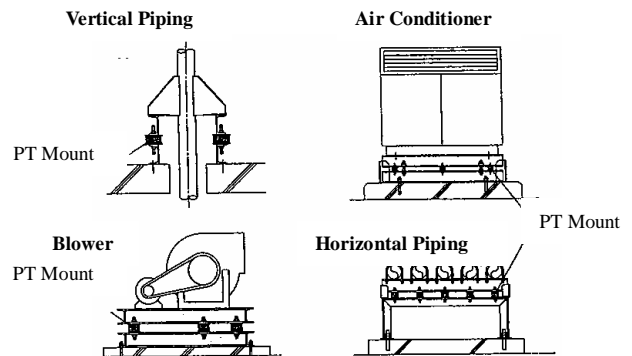

■ Structure

| | | | |
|--|-----|---------------|------------------|
| | No. | Parts | Material |
| | 1 | Bolt | SS400 |
| | 2 | Nut | SS400 |
| | 3 | Spring Washer | SWRH |
| | 4 | Metal Fitting | SS400 |
| | 5 | Rubber | Synthetic Rubber |
| <ul style="list-style-type: none"> • Metal part is chrome-plated. | | | |

■ Dimensions

| | | | | | | | |
|--------|-----|------|----|-----|------------|-----------------------------|------------|
| PTM-01 | 20 | 15 | 18 | M6 | 167 (17) | 98 to 245 (10 to 25) | 23 to 15 |
| PTM-02 | 25 | 17.5 | 18 | M6 | 164 (17) | 196 to 392 (20 to 40) | 17 to 12 |
| PTM-04 | 35 | 26 | 23 | M8 | 181 (18) | 294 to 735 (30 to 75) | 14 to 8.9 |
| PTM-06 | 45 | 34 | 23 | M8 | 202 (21) | 588 to 1079 (60 to 110) | 11 to 7.8 |
| PTM-08 | 55 | 40 | 32 | M10 | 290 (30) | 785 to 1716 (80 to 175) | 11 to 7.4 |
| PTM-09 | 65 | 34 | 37 | M12 | 647 (66) | 1373 to 3138 (140 to 320) | 12 to 8.2 |
| PTM-10 | 75 | 41 | 37 | M12 | 612 (62) | 2550 to 3923 (260 to 400) | 8.8 to 7.1 |
| PTM-11 | 90 | 49 | 37 | M12 | 689 (70) | 3138 to 5394 (320 to 550) | 8.4 to 6.4 |
| PTM-12 | 110 | 65 | 46 | M16 | 842 (86) | 4413 to 9316 (450 to 950) | 7.8 to 5.4 |
| PTM-13 | 150 | 68 | 51 | M20 | 1821 (186) | 7845 to 19613 (800 to 2000) | 8.7 to 5.5 |



Notice for Handling

- Avoid scratches on Products.
- Avoid contact with strong acid, strong alkali, organic solvent, oils and fats.
- Install products so that load is added equally to compression direction.
- Use products within allowable load range.
- Avoid spatters on products.

ISO 9000 Approval



Objects are for Design, Development and Manufacture of Rubber joint, Resin joint and Vibration-proof products.

Square Type

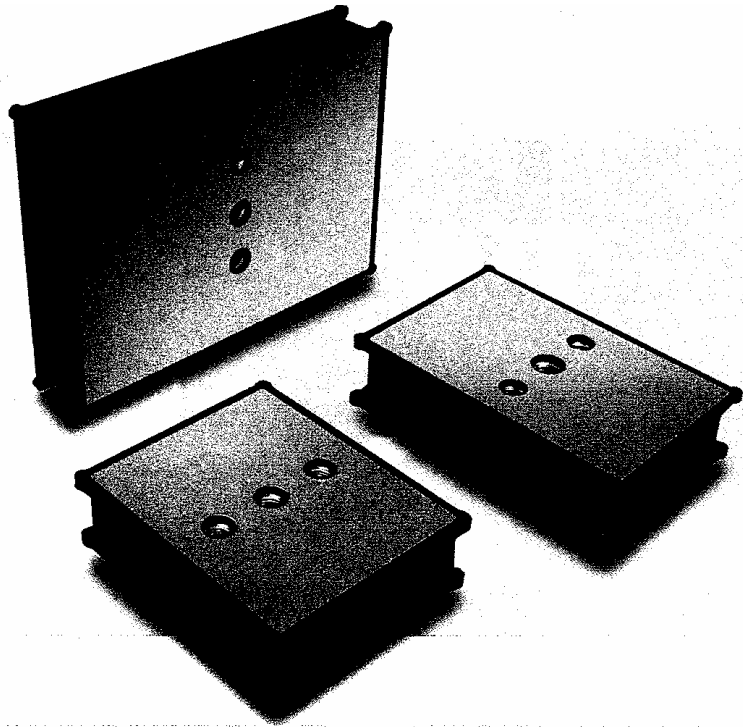

Vibration-proof products for Heavy load

Easy Installation

Easy installation with female construction

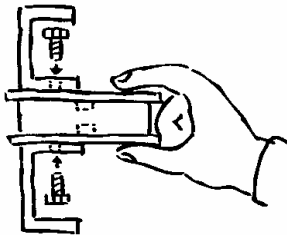

Multi-purpose Application at Low Cost

5 types ranging from 3 tons to 10 tons

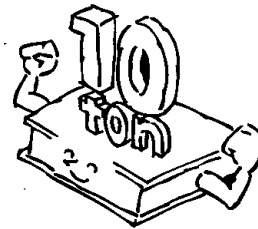

Feature

- Possible to insert Vibration-proof rubber into narrow clearance space because mounting is set with female thread construction.
- Can be used for steel structure such as H section and channel because mounting parts are provided at 3 points.

Application

Can be used as vibration-proof support such as supporting load for vertical piping with large size, stopper for seismic-proof, large equipment for facility, three-dimension parking garage, machine tool and main structure for buildings.

Example for Installation

Vertical Piping of large diameter

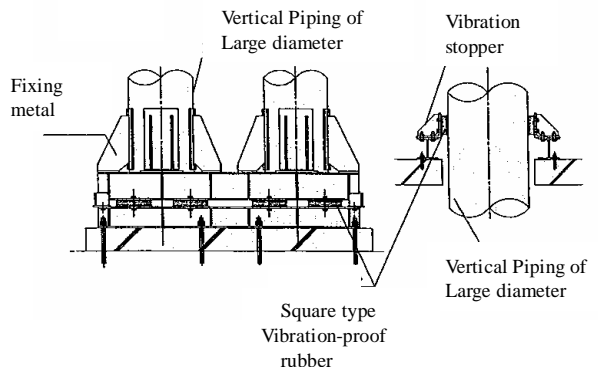

■ Structure

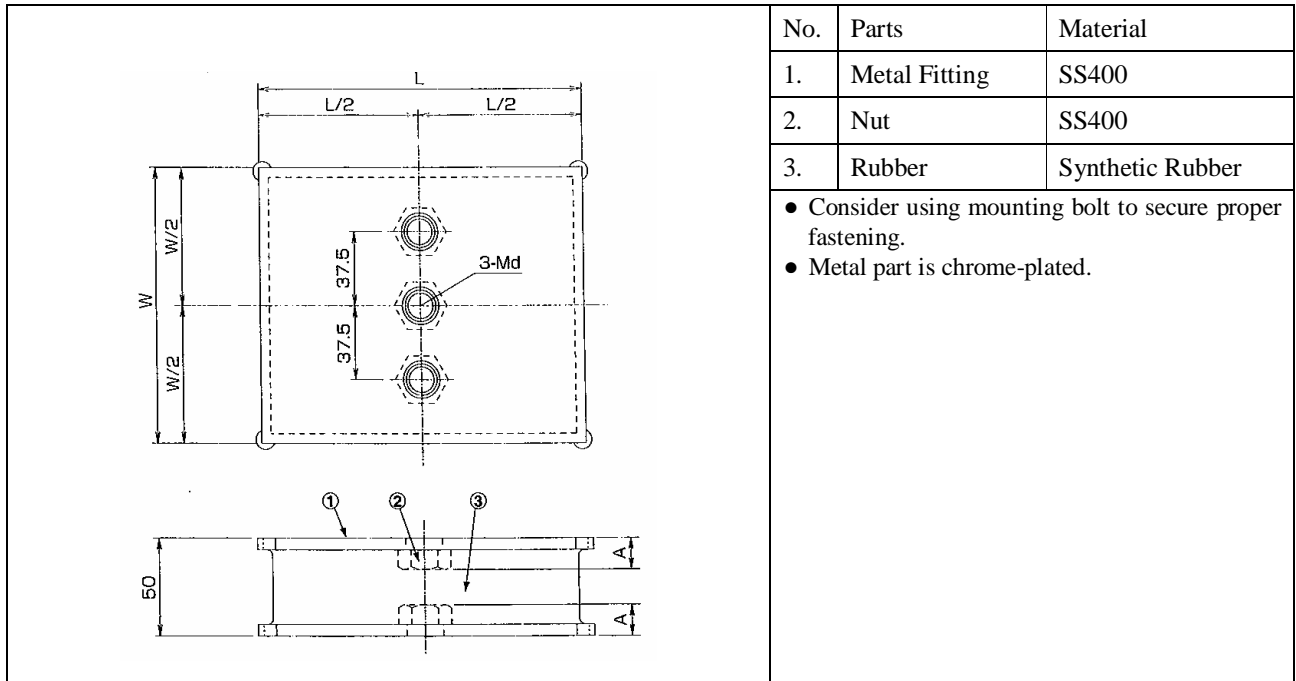

| No. | Parts | Material |
|-----|---------------|------------------|
| 1. | Metal Fitting | SS400 |
| 2. | Nut | SS400 |
| 3. | Rubber | Synthetic Rubber |

- Consider using mounting bolt to secure proper fastening.
- Metal part is chrome-plated.

■ **Dimensions**

| Model | Dimensions (mm) | | | | Static Spring Constant N/mm (kgf/mm) | Allowable Load N (kgf) |
|-------|-----------------|-----|-----|----|---|---------------------------|
| | W | L | Md | A | | |
| R1414 | 140 | 140 | M12 | 13 | 4,864 (496) | 29,420 (3,000) |
| R1417 | 140 | 170 | M16 | 16 | 6,590 (672) | 39,227 (4,000) |
| R1421 | 140 | 210 | M16 | 16 | 8,875 (905) | 49,033 (5,000) |
| R1625 | 160 | 250 | M16 | 16 | 12,925 (1318) | 68,647 (7,000) |
| R2028 | 200 | 280 | M20 | 20 | 20,388 (2079) | 98,067 (10,000) |



Notice for Handling

- Avoid scratches on Products.
- Avoid contact with strong acid, strong alkali, organic solvent, oils and fats.
- Install products so that load is added equally to compression direction.
- Use products within allowable load range.
- Avoid spatters on products.

ISO 9000 Approval



Objects are for Design, Development and Manufacture of Rubber joint, Resin joint and Vibration-proof products.

Hanging Type

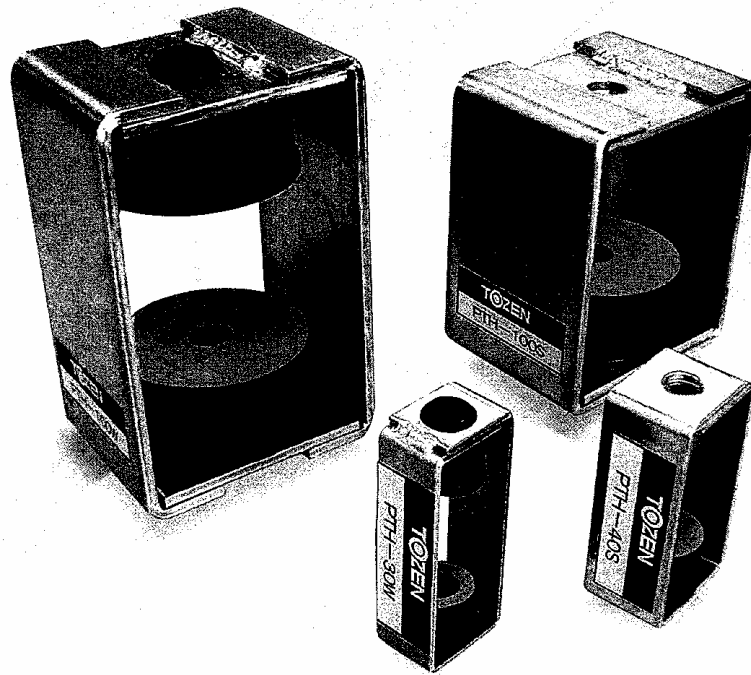

Vibration-proof for Piping and Duct

Rubber is integrated with Case.

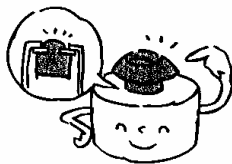

**Excellent Performance for
Insulation of Vibration**

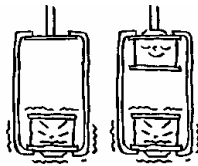

Various Sizes available

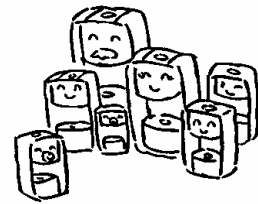

Feature

- Wide size range provides support from light load to heavy load.
- Easy installation as rubber is integrated with case.
- Double nut mounting is possible for special specification.
- Single type and Double type provides selection corresponding to application.

Application

Vibration-proof rubber use for Hanging Supports for equipment or facility such as Horizontal piping, Duct, Blower, Fan-coil unit, Package air conditioner and Pump, etc.

Example for Installation

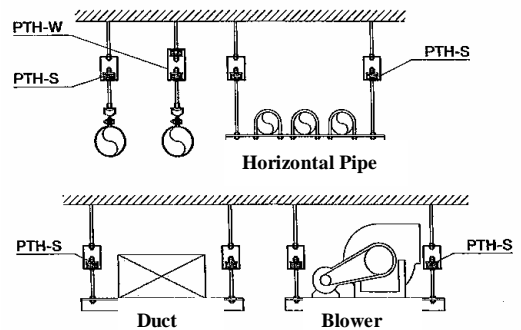

■ Structure

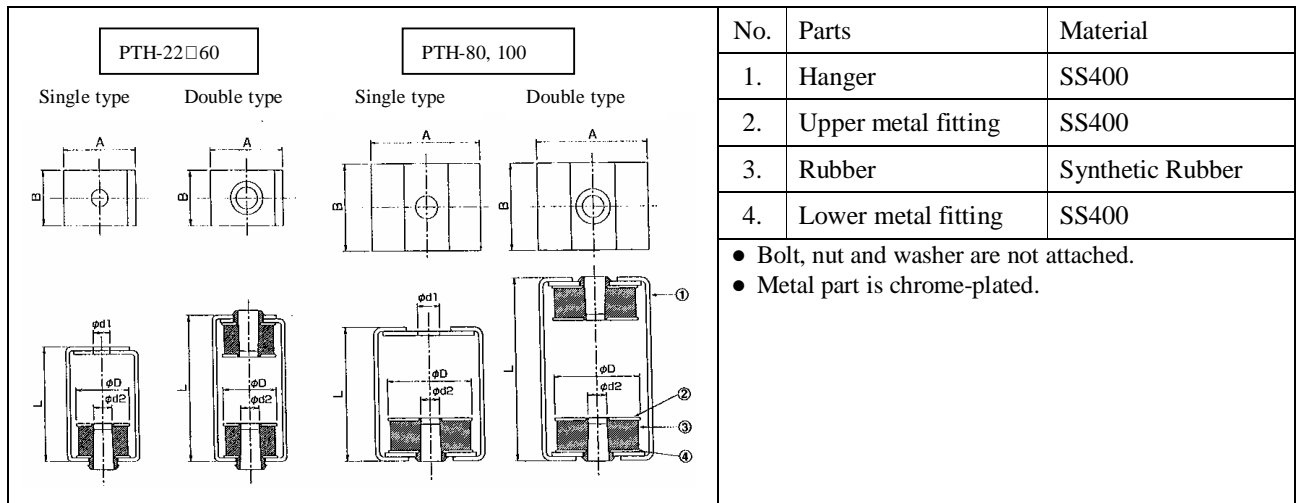

Note : Drawing and Dimensions A, B will be changed later.

■ **Dimensions** (S; Single type, W; Double type)

| Model | Dimensions (mm) | | | | | | Max. Bolt Dia. | Static Spring Constant N/mm (kgf/mm) | Operating Load Range N (kgf) | Natural Frequency Hz | |
|-----------|-----------------|-----|-----|------|------|-----|----------------|---|---------------------------------|---------------------------|-----------|
| | A | B | L | f φ1 | f φ2 | f φ | | | | | |
| PTH-22S | 22 | 34 | 85 | 11 | 10.5 | 22 | M10 (W3/8) | 35 (3.6) | 69 to 147 (7 to 15) | 13 to 8.8 | |
| PTH-22W | | | 110 | --- | | | | 18 (1.8) | | 9.2 to 6.3 | |
| PTH-30S | 30 | 44 | 90 | 11 | 12 | 30 | | 137 (14) | | 98 to 441 (10 to 45) | 21 to 10 |
| PTH-30W | | | 110 | --- | | | | 69 (7.0) | 15 to 7.1 | | |
| PTH-40S | 40 | 55 | 105 | 15 | 14 | 40 | | M12 (W1/2) | 216 (22) | 294 to 883 (30 to 90) | 15 to 8.9 |
| PTH-40W | | | 130 | --- | | | | | 108 (11) | | 11 to 6.3 |
| PTH-50S | 50 | 66 | 105 | 15 | 14 | 50 | 490 (50) | | 686 to 1765 (70 to 180) | | 15 to 9.5 |
| PTH-50W | | | 130 | --- | | | 245 (25) | | | 11 to 6.7 | |
| PTH-60S | 60 | 76 | 110 | 15 | 14 | 60 | 647 (66) | | | 1373 to 2746 (140 to 280) | 12 to 8.7 |
| PTH-60W | | | 140 | --- | | | 324 (33) | | 8.7 to 6.2 | | |
| PTH-80S | 80 | 100 | 130 | 18 | 16 | 80 | 785 (80) | 2157 to 4903 (220 to 500) | 11 to 7.2 | | |
| PTH-80W | | | 170 | --- | | | 392 (40) | | 7.7 to 5.1 | | |
| PTH-100S | 100 | 130 | 160 | 20 | 20 | 100 | 1157 (118) | | 3923 to 8336 (400 to 850) | 9.8 to 6.7 | |
| PTH-100W | | | 205 | --- | | | 579 (59) | 6.9 to 4.7 | | | |
| PTH-100hS | 100 | 130 | 160 | 20 | 20 | 100 | 1863 (190) | 6865 to 12749 (700 to 1300) | | 9.4 to 6.9 | |
| PTH-100hW | | | 205 | --- | | | 932 (95) | | 6.6 to 4.9 | | |



Notice for Handling

- Avoid scratches on Products.
- Avoid contact with strong acid, strong alkali, organic solvent, oils and fats.
- Install products so that load is added equally to vertical and compression direction to rubber.
- Use products within allowable load range.
- Avoid spatter on products.
- Install products with double nut.
- In the case of support for pipes, added other weight such as valve, flange, etc.
- In the case of hanging plural number of piping, select products after calculating load to be added to each hanging bolt.
- Though products are assembled, parts might come off as result of shock or unjustified forces.

ISO 9000 Approval



Objects are for Design, Development and Manufacture of Rubber joint, Resin joint and Vibration-proof products.

Place Type

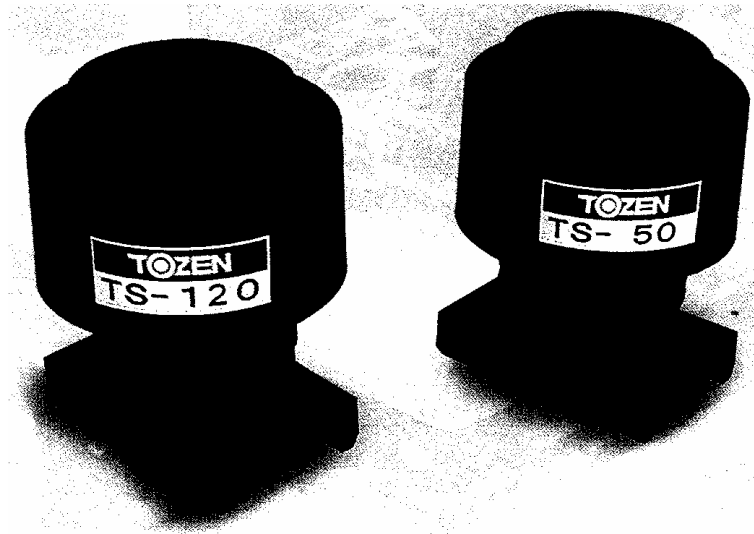

Realized Higher Vibration Absorption

Low Cost and High Performance

Natural Frequency:

Suitable Load is clear.

Realization of 3.1 Hz

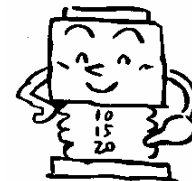
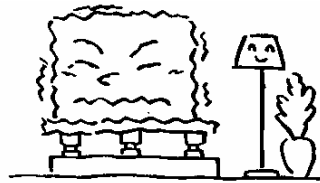

Feature

- Can be used outdoor as case is made of weatherproof material.
- Can be used for every kind of upper pedestal receiver as shape of product is round.
- 5 types of rubber pedestal are available with width ranging from 40 mm to 75 mm for lower pedestal receiver.
- Offers higher vibration-proof effect, as natural frequency of 3.1 Hz to 4 Hz is realized.

Application

Vibration-proof product use for Pump, Blower, Package air conditioner, Chilling unit, Air conditioner and Cooling tower, etc.

Example for Installation

Air conditioner

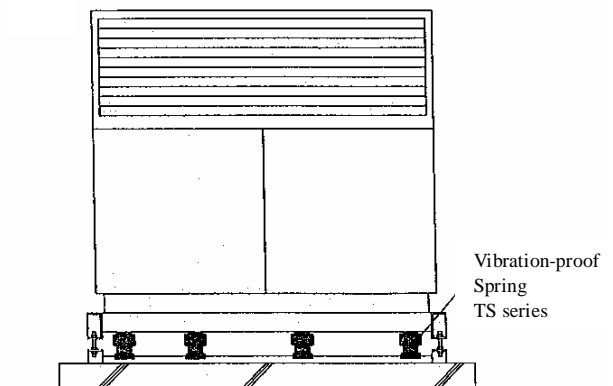

■ Structure

